

described in terms of a single electron shift.^{9,10} For a regular cation an electron shift from N: to R⁺ converts the electronic configuration describing reactants, the DA configuration, **1**, to

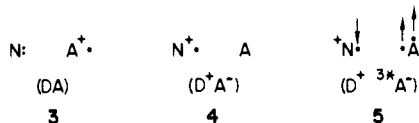

that describing the N-R combination product, D⁺A⁻, **2**. The case of a radical cation is, however, quite different. A single electron shift from the nucleophile to the radical cation A⁺ cannot lead to nucleophilic addition. Conversion of **3** to **4** by a single electron



shift (DA → D⁺A⁻) merely generates the parent hydrocarbon, A, together with N⁺. The absence of an odd electron on A after the electron shift precludes N--A coupling, so that the net result of an electron shift, if it were to occur, would lead to just electron transfer.

Is direct nucleophilic attack on a radical cation then at all possible? The answer is yes, but the pathway is predicted to be a high-energy one and hence the term forbidden. The electronic configuration that describes the product of nucleophilic addition to a radical cation is shown in **5** and may be designated as D⁺³A⁻. The addition product, N⁺-A, is described by **5** since the odd electron on N may couple up with one of the uncoupled electrons on A to generate a covalent bond. Direct nucleophilic attack on a radical cation is therefore a high-energy process since **5** is doubly excited with respect to **3**. In order to transform **3** to **5**, an electron must be transferred from the nucleophile to the radical cation and then the latter excited to the triplet state. An energy diagram, Figure 1, schematically illustrates how a doubly excited product configuration, D⁺³A⁻, is expected to lead to a higher barrier¹¹ than a singly excited product configuration, D⁺A⁻. The idea that the energy of the excited state in part governs the barrier height for ground-state reactions is a central element of Marcus theory¹² and has been frequently applied in the quantitative application of the CM model.^{7c,8b,e} However, in these prior applications, it is a variation in the energy of a given excited state (D⁺A⁻) that was considered to affect the barrier height rather than an actual change in the identity of the excited state, as suggested here.

Of course, nucleophilic attack on the dication is predicted to take place readily. Formation of the radical cation species as a consequence of an electron shift from N: to A²⁺ leads to a N⁺·A⁺ radical pair which can collapse to give N⁺-A⁺. Similarly, reaction of a radical cation with a radical is also predicted to be a facile process. Here the electronic configuration of the reactants, A⁺·R, is identical with that of product so that in electronic terms the reaction is predicted to be barrier free.

In summary, viewing polar processes in terms of a single electron shift has far-reaching consequences. Our analysis suggests that polar processes, described by just a single electron shift (a DA-D⁺A⁻ crossing), may be classified as allowed, while those whose

products need to be described by a doubly excited configuration (e.g., D⁺³A⁻) may be classified as forbidden.³ Other reactivity problems also appear amenable to this simple theoretical treatment and will be discussed in a full paper.

Acknowledgment. I am pleased to thank Professors L. Ebersson, D. Kost, and S. S. Shaik for helpful comments.

Synthesis and Characterization of a Confacial Biocuboidal Tantalum(II) Dimer with a Formal Triple Metal-Metal Bond

F. Albert Cotton,* Michael P. Diebold, and Wieslaw J. Roth

Department of Chemistry and Laboratory for Molecular Structure and Bonding, Texas A&M University College Station, Texas 77843

Received February 19, 1986

Since the discovery of quadruple bonds between metal atoms an extensive chemistry involving dinuclear complexes with multiple metal-metal bonds has been developed for a number of transition elements.^{1,2} For the heavier group 5 metals, Nb and Ta, compounds with the metal-metal bond order up to 2 have been recognized.³ The triple bond, while viable on theoretical grounds, has been elusive. It was expected to occur for these metals in the oxidation state +2, but so far no Nb or Ta dimer with the d³-d³ electronic configuration and strong interactions between metal atoms has been shown to exist. In general the area of M(II) species, M = Nb or Ta, is practically unexplored and relatively few compounds are known. They include monomeric, octahedral phosphine adducts of the type MX₂L₄, where X = Cl⁴ or OAr.⁵ Recently two dinuclear Nb(II) compounds, containing η⁵-C₅H₅ and CO, have been reported but the long Nb-Nb distance of ca. 3.06 Å indicates the presence of a single bond between metal atoms.

We postulated that M(III) dimers with a double bond, spanned by a bidentate bridging ligand which would maintain the close proximity of metal atoms, had a potential for providing the desired d²-d² species upon reduction. Several such compounds have been prepared, namely, Ta₂Cl₅(O₂C-*t*-Bu)(SMe₂)(THF)₂,⁷ [Nb₂Cl₂(O₂CCH₃)₂(THT)]⁻,⁸ and M₂Cl₆(dmpm)₂,^{3c} where THT is tetrahydrothiophene and dmpm is bis(dimethylphosphino)methane. All three reacted with sodium amalgam but the products were found to be rather intractable. However, in the case of the first compound, with THT instead of SMe₂, the treatment with *t*-BuCO₂Li (intended to produce ditantalum tetracarboxylate if a Ta-Ta moiety was present) afforded after workup a small amount (10-15% based on Ta) of red crystalline material. Although its composition determined by single-crystal X-ray analysis^{9,10} was

(1) Cotton, F. A.; Walton, R. A. *Multiple Bonds between Metal Atoms*; Wiley: New York, 1982.

(2) Cotton, F. A.; Walton, R. A. *Struct. Bonding (Berlin)* **1985**, *62*, 1.

(3) (a) Templeton, J. L.; McCarley, R. E. *Inorg. Chem.* **1978**, *17*, 2293.

(b) Sattelberger, A. P.; Wilson, R. B.; Huffman, J. C. *Inorg. Chem.* **1982**, *21*, 2392. (c) Cotton, F. A.; Roth, W. J. *Inorg. Chem.* **1983**, *22*, 3654. (d)

Cotton, F. A.; Duraj, S. A.; Roth, W. J. *Acta Crystallogr. Sect. C* **1985**, *C41*, 876. (e) Chakravarty, A. R.; Cotton, F. A.; Diebold, M. P.; Lewis, D. B.; Roth, W. J. *J. Am. Chem. Soc.* **1986**, *108*, 971. (f) Morancas, J. L.; Hubert-Pfalzgraf, L. G. *Inorg. Chim. Acta* **1983**, *71*, 119.

(4) Luetkens, M. L.; Huffman, J. C.; Sattelberger, A. P. *J. Am. Chem. Soc.* **1983**, *105*, 4474.

(5) Coffindaffer, T. W.; Rothwell, I. P.; Folting, K.; Huffman, J. C.; Streib, W. E. *J. Chem. Soc., Chem. Commun.* **1985**, 1519.

(6) Curtis, M. D.; Real, J. *Organometallics* **1985**, *4*, 940.

(7) Cotton, F. A.; Diebold, M. P.; Duraj, S. A.; Roth, W. J. *Polyhedron* **1985**, *4*, 1479.

(8) Cotton, F. A.; Diebold, M. P.; Matusz, M.; Roth, W. J. *Inorg. Chim. Acta* **1986**, *112*, 147.

(9) Crystal structure determinations were carried out by standard methods, which have been described previously: (a) Bino, A.; Cotton, F. A.; Fanwick, P. E. *Inorg. Chem.* **1979**, *18*, 3558. (b) Cotton, F. A.; Frenz, B. A.; Deganello, G.; Shaver, A. J. *Organomet. Chem.* **1973**, *50*, 227.

(9) In this paper we distinguish the terms "electron transfer" and "electron shift". *Electron transfer* refers to a simple redox process in which the overall change that has occurred is the transfer of a single electron. This is in agreement with current usage. *Electron shift* is a more general term that includes both electron transfer processes as well as those cases in which the change in the position of the electron is coupled to bonding changes.¹⁰ Thus polar reactions which involve a DA-D⁺A⁻ avoided crossing are termed electron shift. Electron shift processes do not necessarily result in free radical formation.

(10) Pross, A. *Acc. Chem. Res.* **1985**, *18*, 212.

(11) Both DA and D⁺³A⁻ are in the doublet state, hence the crossing (between two states of the same multiplicity) is avoided.

(12) (a) Marcus, R. A. *Annu. Rev. Phys. Chem.* **1964**, *15*, 155. (b) Marcus, R. A. In *Special Topics in Electrochemistry*; Rock, P. A., Ed.; Elsevier: Amsterdam, 1977.

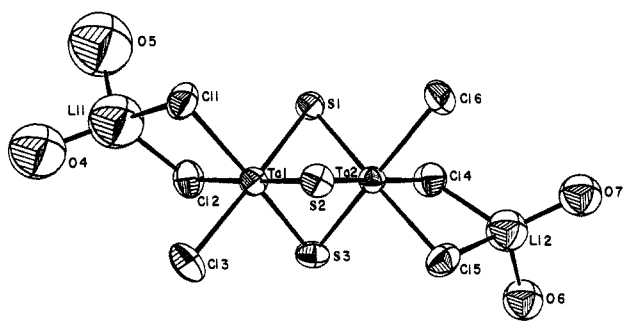

Figure 1. ORTEP drawing of the $[\text{Ta}_2\text{Cl}_6(\text{THT})_3][\text{Li}(\text{THF})_2]$ molecule. Carbon atoms of the THF and THT rings have been omitted for the sake of clarity. Thermal ellipsoids enclose 40% of electron density. Ta, S, and Cl atoms were refined anisotropically. Important, averaged interatomic dimensions: Ta(1)–Ta(2), 2.626 (1) Å; Ta–S, 2.392 [4] Å; Ta–Cl, 2.494 [3] Å; Ta–Cl(Li), 2.525 [6] Å; Li–Cl, 2.42 [2] Å; Li–O, 1.96 [5] Å; Ta–S–Ta, 66.3 [2]°; S–Ta–S, 92.7 [4]°.

quite surprising, viz., $[\text{Li}(\text{THF})_2]_2[\text{Ta}_2(\mu\text{-THT})_3\text{Cl}_6]$, it was a Ta(II) dimer with a short metal–metal distance (vide infra).¹¹ The original synthetic procedure was reproducible, but since it was too elaborate and not very efficient, a superior method was subsequently developed. It involves reduction of $\text{Ta}_2\text{Cl}_6(\text{THT})_3$ in THF with 2 equiv of sodium amalgam in the presence of LiCl. The product is isolated in high yield (>60%) after filtration and addition of hexane. The proton NMR spectrum¹² in acetonitrile- d_3 indicates that the complex is diamagnetic and all three THT ligands are equivalent. The tetrabutylammonium derivative was also prepared, by cation exchange, and its crystallographic characterization carried out.¹³

The molecular structure determinations of both the lithium and tetra-*n*-butylammonium salts revealed discrete confacial bioctahedra with a $\text{Ta}_2(\mu\text{-S})_3\text{Cl}_6$ frame. An ORTEP drawing of the former is shown in Figure 1 and important interatomic dimensions are listed in the figure caption. The most notable feature of the dinuclear anion is the short Ta–Ta distance of about 2.62 Å. It is distinctly shorter than the double bonds in species of the type $\text{M}_2\text{X}_6\text{L}_3$ and $\text{M}_2\text{X}_6\text{L}_4$, M = Nb and Ta, with bridging atoms from the third period (the typical distance is around 2.7 Å, and the shortest observed is equal 2.6695 (5) Å). This together with the $d^3\text{-}d^3$ electronic configuration and diamagnetism of the compound indicates the presence of a formal triple Ta–Ta bond. A more detailed description of metal–metal bonding is difficult because the presence of three bridging atoms usually complicates the

interpretation of the interactions between central atoms in confacial bioctahedra.¹⁴ In addition, since analogous compounds with other transition metals are apparently unknown the discussion of metal–metal interactions based upon comparison of relevant interatomic dimensions presents problems as well. The nonhalometalates are not appropriate for the purpose as they do not exhibit a straightforward relationship between the number of d electrons and the M–M distance.¹⁴ Among the M_2X_6 species there are a few compounds with some degree of similarity to $[\text{Ta}_2(\text{THT})_3\text{Cl}_6]^{2-}$. They are $\text{Mo}_2\text{Cl}_6(\text{SMe}_2)_3$,¹⁵ which has a similar composition, and $\text{W}_2\text{Cl}_4(\text{SEt})_3(\text{SMe}_2)_2$ ¹⁶ which has the same $\text{M}_2(\mu\text{-S})_3$ central core. These complexes have formal metal–metal bonds order of 3 and 2.5, respectively, with the M–M bond lengths equal 2.462 (2) and 2.505 (1) Å, respectively. The difference of ca. 0.16 Å between the triple bond of Mo and Ta is not particularly abnormal. The former usually forms stronger bonds than Nb and Ta which have more diffuse d orbitals. This seems to be reflected in shorter M–Cl(terminal) distances for Mo and W but the different nature of trans ligands can also be a factor in this case.

The isolation of the Ta(II) dimer has important consequences. It provides the basis for the preparation of related Nb species and possibly compounds with unsupported triple metal–metal bonds of the type M_2X_8 . A more complete report including discussion of the electronic structure will be submitted later.

Acknowledgment. We thank the Robert A. Welch Foundation (Grant A-494) for support.

Supplementary Material Available: Table of positional and isotropic equivalent thermal parameters for $[\text{Li}(\text{THF})_2]_2[\text{Ta}_2\text{Cl}_6(\text{THT})_3]$ (3 pages). Ordering information is given on any current masthead page.

(14) (a) Cotton, F. A.; Ucko, D. *Inorg. Chim. Acta* **1972**, *6*, 161. (b) Summerville, R. H.; Hoffmann, R. *J. Am. Chem. Soc.* **1979**, *101*, 3821. (c) Cotton, F. A.; Falvello, L. R.; Mott, G. N.; Schrock, R. R.; Sturgesoff, L. G. *Inorg. Chem.* **1983**, *22*, 2621.

(15) Boorman, P. M.; Moynihan, K. J.; Oakley, R. T. *J. Chem. Soc., Chem. Commun.* **1982**, 899.

(16) Boorman, P. M.; Patel, V. D.; Kerr, K. A.; Codding, P. W.; Van Roey, P. *Inorg. Chem.* **1980**, *19*, 3508.

Concerning the Mode of Reaction of the Proposed Ultimate Metabolite of the Carcinogen 4-Nitroquinoline 1-Oxide. Evidence for Intermediacy of Nitrenium Ions[†]

Martine Demeunynck,^{1a} Najat Tohmé,^{1a}
Marie-France Lhomme,^{1a} John M. Mellor,^{1b} and
Jean Lhomme^{*1a}

Laboratoire de Chimie Organique Biologique
UA CNRS 351, Université de Lille I
59655 Villeneuve d'Ascq Cedex, France
Department of Chemistry, The University
Southampton SO9 5NH, England

Received July 22, 1985

Esters of *N*-hydroxy-*N*-arylacetyl amides, such as **1**, are considered to be the reactive metabolites of mutagenic and carcinogenic aromatic amides.² Reaction with purines and pyrimidines in DNA has been discussed^{2,3} on the basis of a key N–O heterolysis to give an acylnitrenium ion intermediate such as **2**. However, an al-

(10) Calculations were done on the VAX-11/780 computer at the Department of Chemistry, Texas A & M University, College Station, TX, with the VAX-SPD software package.

(11) The complex crystallizes in the triclinic space group $P\bar{1}$ with $a = 10.622$ (1) Å, $b = 22.468$ (3) Å, $c = 10.581$ (2) Å, $\alpha = 103.37$ (1)°, $\beta = 119.28$ (1)°, $\gamma = 85.31$ (1)°, $V = 2142$ (1) Å³, $Z = 2$, $d_{\text{calcd}} = 1.779$ g/cm³ for $\text{fw} = 1141.43$. Refinement of 236 parameters using 3053 reflections with $F^2 > 3\sigma(F^2)$ produced residuals R and R_w equal to 0.062 and 0.076, respectively. The crystallographic analysis was routine without unusual problems. The apparent loss of THF during data collection (ca. 40% decay) resulted in high thermal parameters for light atoms. It did not, however, affect the refinement to a significant degree. The light Li atoms were located in the difference Fourier map and their presence is unquestionable in view of the arrangement of the THF molecules. The table of positional and isotropic equivalent thermal parameters is provided as supplementary material.

(12) The spectra were recorded on a Varian EM-390 NMR spectrometer. The proton resonances appeared as multiplets with the following chemical shifts (in ppm, vs. Me_4Si): THF 3.55 and 1.66; μ_2 -THT 3.00 and 2.06; acetonitrile 1.79; free THT (small peaks) 2.50 and 1.69.⁸ Repeated washing of the solid with hexane removed the free ligand but there was also partial loss of THF.

(13) The salt crystallizes in a noncentrosymmetric orthorhombic space group $Pc2_1a$ (No. 29) with $a = 11.646$ (3) Å, $b = 22.250$ (6) Å, $c = 22.833$ (6) Å, $Z = 4$, $V = 5913$ (3) Å³, and $d_{\text{calcd}} = 1.487$ g/cm³ for $\text{fw} = 1324.06$. The intensity data set was of poor quality, apparently due to unfavorable mosaic spread. There was very little X-ray scattering above $2\theta = 30^\circ$ and all atoms, including Ta, had high thermal parameters. The whole $\text{Ta}_2\text{Cl}_6(\text{THT})_3^{2-}$ anion and most atoms in the NBu_4^+ cations were located in the difference Fourier map and refined isotropically. This allowed unequivocal identification of the compound. The interatomic dimensions within the anion compared well with those in the Li derivative.

[†] Dedicated to Professor Guy Ourisson on the occasion of his 60th birthday.

(1) (a) University of Lille. (b) University of Southampton.

(2) Several recent reviews include: Miller, J. A. *Cancer Res.* **1970**, *30*, 559–576. Miller, J. A.; Miller, E. C. *EHP, Environ. Health Perspect.* **1983**, *49*, 3–12. Kriek, E.; Westra, J. G. In *Chemical Carcinogens and DNA*; Grover, P. L., Ed.; CRC Press: Boca Raton, FL, 1979; Vol. 2, pp 1–28. Dalejka-Giganti, D. In *Chemistry and Biology of Hydroxamic Acids*; Kehl, H., Ed.; Karger: Basel, 1982; pp 150–159. Hathway, D. E.; Kolar, G. F. *Chem. Soc. Rev.* **1980**, *9*, 241–264.

(3) Scribner, J. D.; Scribner, N. K. *Experientia* **1975**, *31*, 470–471.